

125 kHz microID™ Passive RFID Device with Anti-Collision

Features

Factory programming and memory serialization (SQTPSM)

- Anti-collision feature to read multiple tags in the same RF field.
- One-time contactless programmable (developer kit only)
- Read-only data transmission after programming
- 96 or 128 bits of One-Time Programmable (OTP) user memory (also supports 48- and 64-bit protocols)
- Typical operation frequency: 100 kHz-400 kHz
- Ultra low-power operation (5 μ A @ $V_{CC} = 2V$)
- Modulation options:
 - ASK, FSK, PSK
- Data Encoding options:
 - NRZ Direct, Differential Biphasic, Manchester Biphasic
- Die, wafer, COB or SOIC package options
- Factory programming options

Applications

- Access control and time attendance
- Security systems
- Animal tagging
- Product identification
- Industrial tagging
- Inventory control
- Multiple item tagging

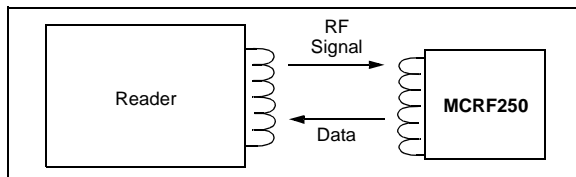

Package Type

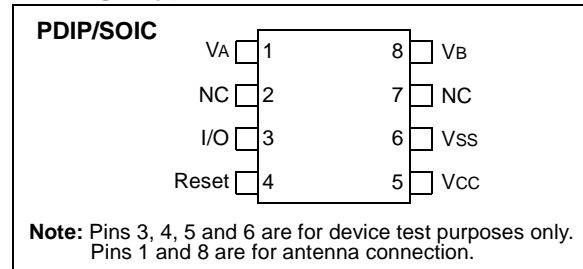

Description

The MCRF250 is equipped with an anti-collision feature that allows multiple tags in the same field to be read simultaneously. This revolutionary feature eliminates the issue of data corruption due to simultaneous transmissions from multiple tags.

The MCRF250 is a passive Radio Frequency Identification (RFID) device for low frequency applications (100 kHz-400 kHz). The device is powered by rectifying an incoming RF signal from a reader interrogator. The device requires an external LC resonant circuit to receive the incoming energizing signal and to send data. The device develops a sufficient DC voltage for operation when its external coil voltage reaches approximately 10 VPP.

This device has a total of 128 bits of user programmable memory and an additional 12 bits in its configuration register. The user can manually program the 128 bits of user memory by using a contactless programmer in a microID developer kit such as DV103001 or PG103001. However, in production volume the MCRF250 is programmed at the factory (Microchip SQTP - see Technical Bulletin TB023). The device is a One-Time Programmable (OTP) integrated circuit and operates as a read-only device after programming.

MCRF250

Block Diagram

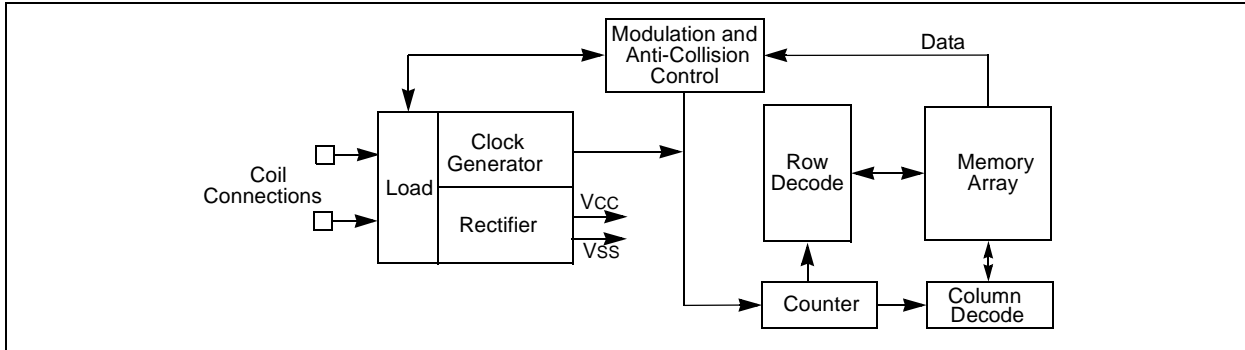

The configuration register includes options for communication protocol (ASK, FSK, PSK), data encoding method, data rate and data length. These options are specified by customer and are factory programmed during production.

The device has a modulation transistor between the two antenna connections (VA and VB). The modulation transistor damps or undamps the coil voltage when it sends data. The variation of coil voltage controlled by the modulation transistor results in a perturbation of voltage in reader antenna coil. By monitoring the changes in reader coil voltage, the data transmitted from the device can be reconstructed.

The device is available in die, wafer, Chip-on-Board (COB) modules, PDIP or SOIC packages. Factory programming and memory serialization (SQTP) are also available upon request. See TB023 for more information on contact programming support.

The DV103002 Developer's Kit includes Contactless Programmer, MCRF250 Anti-Collision FSK reference reader, and reference design guide. The reference design guide includes schematics for readers and contactless programmer as well as in-depth documentation for antenna circuit designs.

1.0 ELECTRICAL CHARACTERISTICS

Absolute Maximum Ratings^(†)

Storage temperature - 65°C to +150°C
 Ambient temperature with power applied..... -40°C to +125°C
 Maximum current into coil pads 50 mA

† **NOTICE:** Stresses above those listed under "Absolute Maximum Ratings" may cause permanent damage to the device. This is a stress rating only and functional operation of the device at those or any other conditions above those indicated in the operation listings of this specification is not implied. Exposure to maximum rating conditions for extended periods may affect device reliability.

TABLE 1-1: AC AND DC CHARACTERISTICS

Parameter	Sym	Min	Typ	Max	Units	Conditions
All parameters apply across the specified operating ranges unless otherwise noted.						
Clock frequency	FCLK	100	—	400	kHz	
Contactless programming time	TWC	—	2	—	sec	For all 128-bit array
Data retention		200	—	—	Years	at 25°C
Coil current (Dynamic)	ICD	—	50		μA	
Operating current	IDD	—	5		μA	VCC = 2V
Turn-on-voltage (Dynamic) for modulation	VAVB	10	—	—	VPP	
	VCC	2	—	—	VDC	
Input Capacitance	CIN	—	2	—	pF	Between VA and VB

MCRF250

2.0 FUNCTIONAL DESCRIPTION

The device contains three major building blocks. They are RF front-end, configuration and control logic, and memory sections. The Block Diagram is shown on page 1.

2.1 RF Front-End

The RF front-end of the device includes circuits for rectification of the carrier, VDD (operating voltage), and high-voltage clamping to prevent excessive voltage from being applied to the device. This section also generates a system clock from the incoming carrier signal and modulates the carrier signal to transmit data to the reader.

2.1.1 RECTIFIER – AC CLAMP

The rectifier circuit rectifies RF voltage on the external LC antenna circuit. Any excessive voltage on the tuned circuit is clamped by the internal circuitry to a safe level to prevent damage to the IC.

2.1.2 POWER-ON RESET

This circuit generates a Power-on Reset when the tag first enters the reader field. The Reset releases when sufficient power has developed on the VDD regulator to allow correct operation.

2.1.3 CLOCK GENERATOR

This circuit generates a clock based on the carrier frequency from the reader. This clock is used to derive all timing in the device, including the baud rate and modulation rate.

2.1.4 IRQ DETECTOR

This circuitry detects an interrupt in the continuous electromagnetic field of the interrogator. An IRQ (interrupt request) is defined as the absence of the electromagnetic field for a specific number of clock cycles. Detection of an IRQ will trigger the device to enter the Anti-collision mode. This mode is discussed in detail in **Section 5.0 “Anti-Collision”**.

2.1.5 MODULATION CIRCUIT

The device sends the encoded data to the reader by AM-modulating the coil voltage across the tuned LC circuit. A modulation transistor is placed between the two antenna coil pads (VA and VB). The transistor turns on and off based on the modulation signal. As a result, the amplitude of the antenna coil voltage varies with the modulation signal. See Figure 2-1 for details.

FIGURE 2-1: MODULATION SIGNAL AND MODULATED SIGNAL

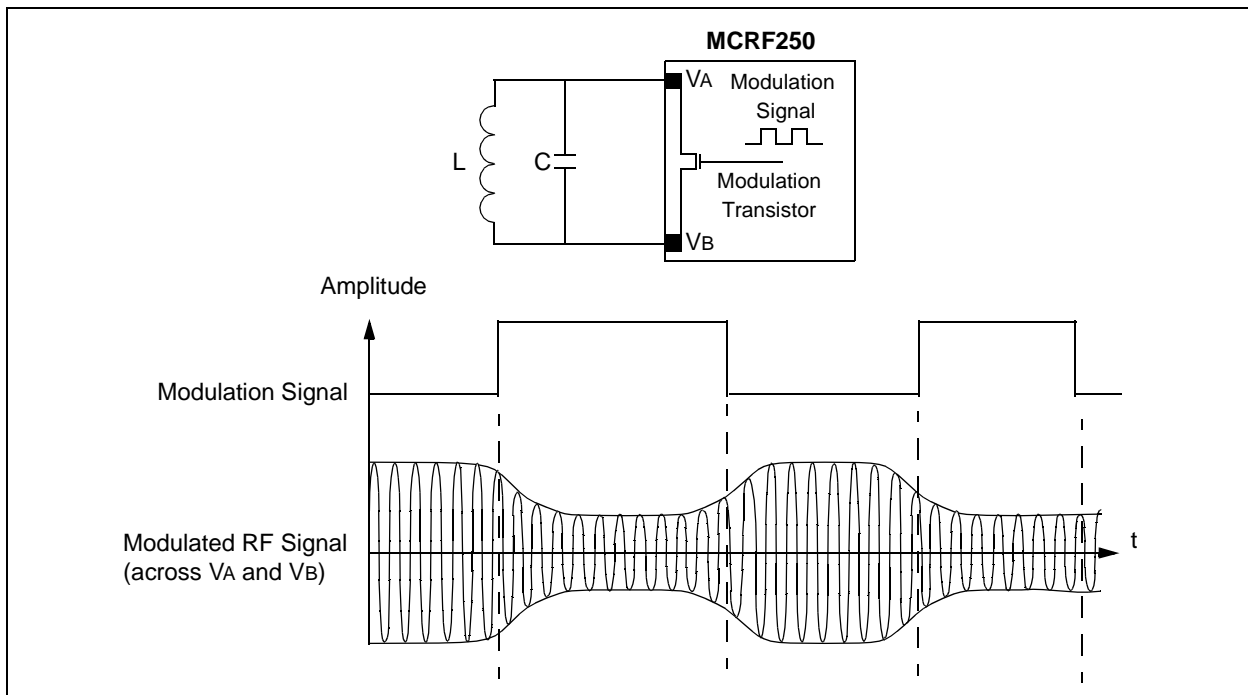

2.2 Configuration Register and Control Logic

The configuration register determines the operational parameters of the device. The configuration register can not be programmed contactlessly; it is programmed during wafer probe at the Microchip factory. CB11 is always a one; CB12 is set when successful contact or contactless programming of the data array has been completed. Once CB12 is set, device programming and erasing is disabled. Table 2-1 contains a description of the bit functions of the control register.

2.2.1 BAUD RATE TIMING OPTION

The chip will access data at a baud rate determined by bits CB2, CB3, and CB4 of the configuration register. For example, MOD32 (CB2 = 0, CB3 = 1, CB4 = 1) has 32 RF cycles per bit. This gives the data rate of 4 kHz for the RF carrier frequency of 128 kHz.

The default timing is MOD 128 ($F_{CLK}/128$), and this mode is used for contact and contactless programming. Once the array is successfully programmed, the lock bit CB12 is set. When the lock bit is set, programming and erasing the device becomes permanently disabled. The configuration register has no effect on device timing until the EEPROM data array is programmed (CB12 = 1).

2.2.2 DATA ENCODING OPTION

This logic acts upon the serial data being read from the EEPROM. The logic encodes the data according to the configuration bits CB6 and CB7. CB6 and CB7 determine the data encoding method. The available choices are:

- Non-return to zero-level (NRZ_L)
- Biphase_S (Differential)
- Biphase_L (Manchester)
- Inverted Manchester

2.2.3 MODULATION OPTION

CB8 and CB9 determine the modulation protocol of the encoded data. The available choices are:

- ASK
- FSK
- PSK_1
- PSK_2

When ASK (direct) option is chosen, the encoded data is fed into the modulation transistor without change.

When FSK option is chosen, the encoded data is represented by:

- a) Sets of 10 RF carrier cycles (first 5 cycles → higher amplitude, the last 5 cycles → lower amplitude) for logic "high" level.
- b) Sets of 8 RF carrier cycles (first 4 cycles → higher amplitude, the last 4 cycles → lower amplitude) for logic "low" level.

For example, FSK signal for MOD40 is represented:

- a) 4 sets of 10 RF carrier cycles for data '1'.
- b) 5 sets of 8 RF carrier cycles for data '0'.

Refer to Figure 2-2 for the FSK signal with MOD40 option.

The PSK_1 represents change in the phase of the modulation signal at the change of the encoded data. For example, the phase changes when the encoded data is changed from '1' to '0', or from '0' to '1'.

The PSK_2 represents change in the phase at the change on '1'. For example, the phase changes when the encoded data is changed from '0' to '1', or from '1' to '1'.

FIGURE 2-2: ENCODED DATA AND FSK OUTPUT SIGNAL FOR MOD40 OPTION

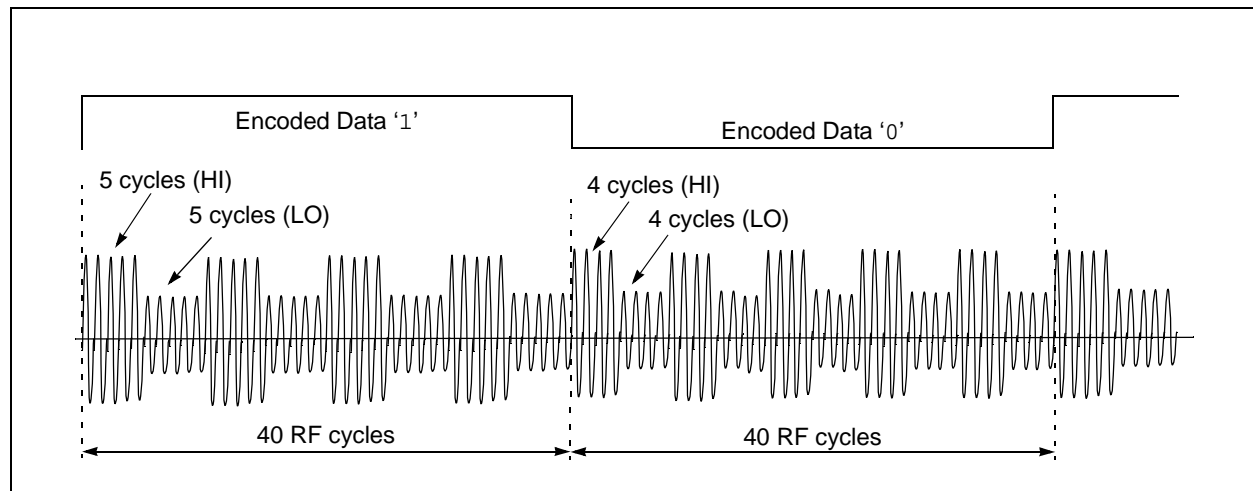

MCRF250

FIGURE 2-3: PSK DATA MODULATION

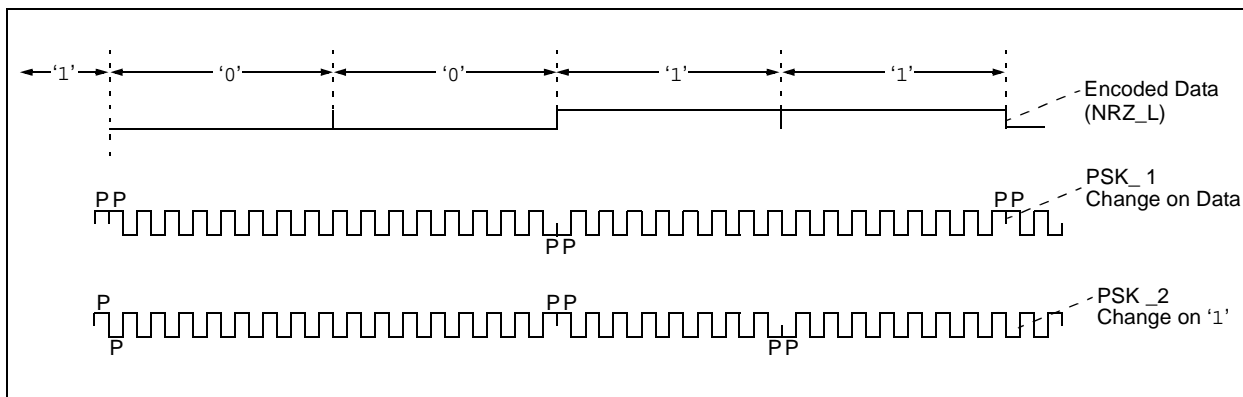

2.2.4 MEMORY ARRAY LOCK BIT (CB12)

The CB12 must be '0' for contactless programming (Blank). The bit (CB12) is automatically set to '1' itself as soon as the device is programmed contactlessly.

2.3 Memory Section

The device has 128 bits of one-time programmable (OTP) memory. The user can choose 96 or 128 bits by selecting the CB1 bit in the configuration register. See Table 2-1 for more details.

2.3.1 COLUMN AND ROW DECODER LOGIC AND BIT COUNTER

The column and row decoders address the EEPROM array at the clock rate and generate a serial data stream for modulation. This data stream can be up to 128 bits in length. The size of the data stream is user programmable with CB1 and can be set to 96 or 128 bits. Data lengths of 48 and 64 bits are available by programming the data twice in the array, end-to-end.

The column and row decoders route the proper voltage to the array for programming and reading. In the programming modes, each individual bit is addressed serially from bit 1 to bit 128.

2.4 Examples of Configuration Settings

EXAMPLE 2-1: "48D" CONFIGURATION

The "48D" (hex) configuration is interpreted as follows:

```

          CB12          CB1
          |             |
"48D" → 0100-1000-1101
    
```

Referring to Table 2-1, the "48D" configuration represents:

- Blank (not programmed) Device
- Anti-Collision
- Modulation = PSK_1
- PSK rate = $rf/2$
- Data encoding = NRZ_L (direct)
- Baud rate = $rf/32 = \text{MOD}32$
- Memory size: 128 bits

EXAMPLE 2-2: "40A" CONFIGURATION

The "40A" (hex) configuration is interpreted as follows:

```

          CB12          CB1
          |             |
"40A" → 0100-0000-1010
    
```

The MSB corresponds to CB12 and the LSB corresponds to CB1 of the configuration register. Therefore, we have:

```

CB12=0   CB11=1   CB10=0   CB9=0
CB8=0    CB7=0    CB6=0    CB5=0
CB4=1    CB3=0    CB2=1    CB1=0
    
```

Referring to Table 2-1, the "40A" configuration represents:

- Not programmed device (blank), anticollision,
- FSK protocol, NRZ_L (direct) encoding, MOD50
- (baud rate = $rf/50$), 96 bits.

Note: The sample cards in the DV103002 kit are configured to "40A".

TABLE 2-1: CONFIGURATION REGISTER

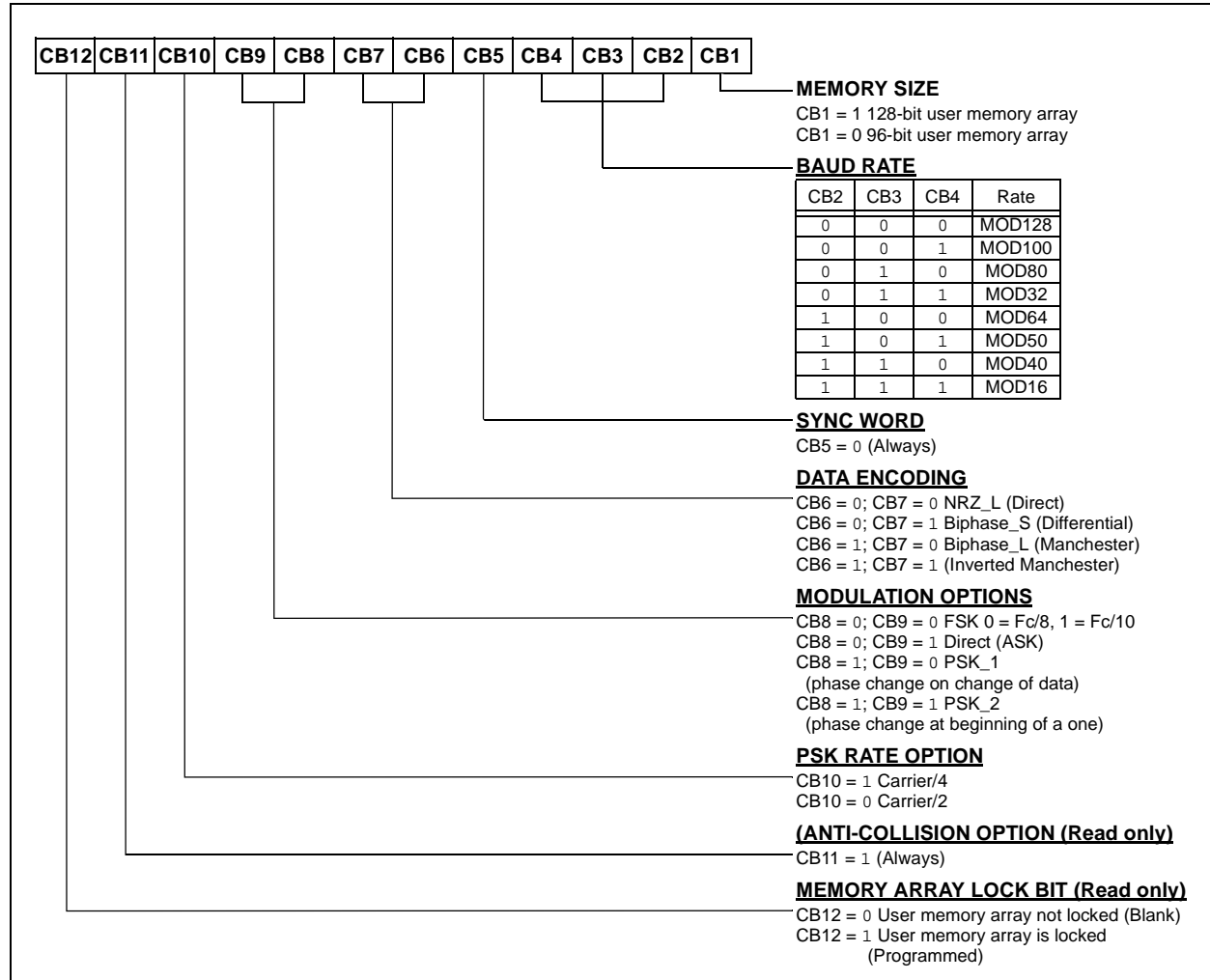

MCRF250

3.0 MODES OF OPERATION

The device has two basic modes of operation: Native Mode and Read Mode.

3.1 Native Mode

Every unprogrammed blank device (CB12 = 0) operates in Native mode, regardless of configuration register settings:

$$\text{Baud rate} = \text{FCLK}/128, \text{FSK, NRZ_L (direct)}$$

Once the user memory is programmed, the lock bit is set (CB12 = 1) which causes the MCRF250 to switch from Native mode to Communication mode defined by the configuration register.

Refer to Figure 4-1 for contactless programming sequence. Also see the *microID™ 125 kHz RFID System Design Guide* (DS51115) for more information.

3.2 Read Mode

After the device is programmed (CB12 = 1), the device is operated in the Read-only mode. The device transmits its data according to the protocol in the configuration register.

FIGURE 3-1: TYPICAL APPLICATION CIRCUIT

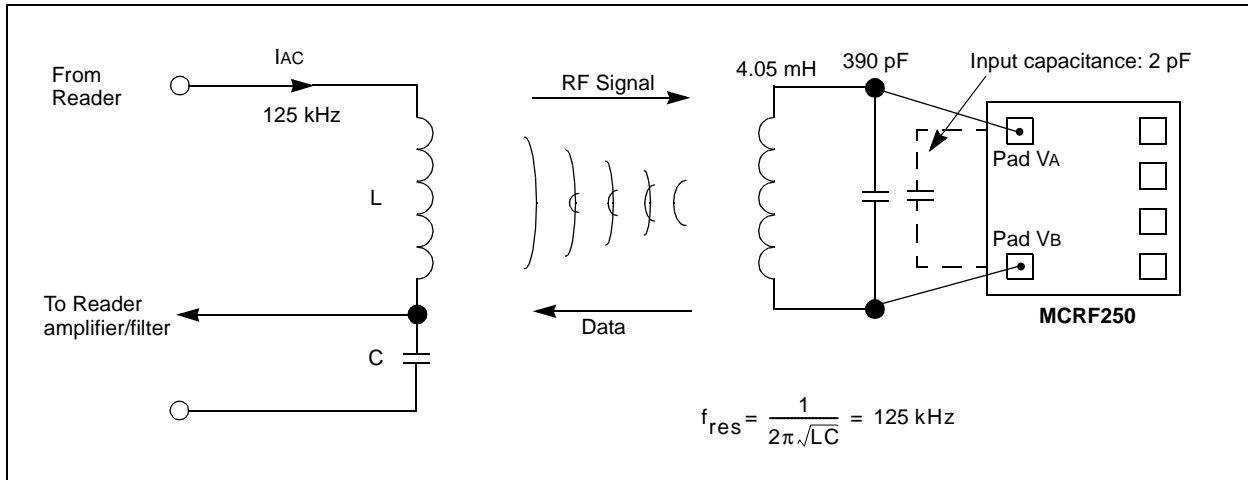

4.0 CONTACTLESS PROGRAMMING

The contactless programming of the device is possible for a blank device (CB12 = 0) only, and is recommended for only low-volume, manual operation during development. In volume production, the MCRF250 is normally used as a factory programmed device only. The contactless programming timing sequence consists of:

- a) RF Power-up signal.
- b) Short gap (absence of RF field).
- c) Verify signal (continuous RF signal).
- d) Programming signal.
- e) Device response with programmed data.

The blank device (CB12 = 0) understands the RF power-up followed by a gap as a blank checking command, and outputs 128 bits of FSK data with all '1's after the short gap. To see this blank data (verify), the reader/programmer must provide a continuous RF signal for 128 bit-time. (The blank (unprogrammed) device has all 'F's in its memory array. Therefore, the blank data should be all '1's in FSK format). Since the blank device operates at Default mode (MOD128), there are 128 RF cycles for each bit. Therefore, the time requirement to complete this verify is 128 bits x 128 RF cycles/bit x 8 use/cycles = 131.1 msec for 125 kHz signal.

As soon as the device completes the verify, it enters the programming mode. The reader/programmer must provide RF programming data right after the verify. In this programming mode, each bit lasts for 128 RF cycles. Refer to Figure 4-1 for the contactless programming sequence.

Customer must provide the following specific voltage for the programming:

1. Power-up and verify signal = 13.5 V_{PP} ±1 V_{PP}
2. Programming voltage:
 - To program bit to '1': 13.5 V_{PP} ±1 V_{PP}
 - To program bit to '0': 30 V_{PP} ±2 V_{PP}

After the programming cycle, the device outputs programmed data (response). The reader/programmer can send the programming data repeatedly after the device response until the programming is successfully completed. The device locks the CB12 as soon as the programming mode (out of field) is exited and becomes a read-only device.

Once the device is programmed (CB12 = 1), the device outputs its data according to the configuration register.

The PG103001 (Contactless Programmer) is used for the programming of the device. The voltage level shown in Figure 4-1 is adjusted by R5 and R7 in the contactless programmer. Refer to the *MicroID™ 125 kHz RFID System Design Guide (DS51115)* for more information.

MCRF250

FIGURE 4-1: CONTACTLESS PROGRAMMING SEQUENCE

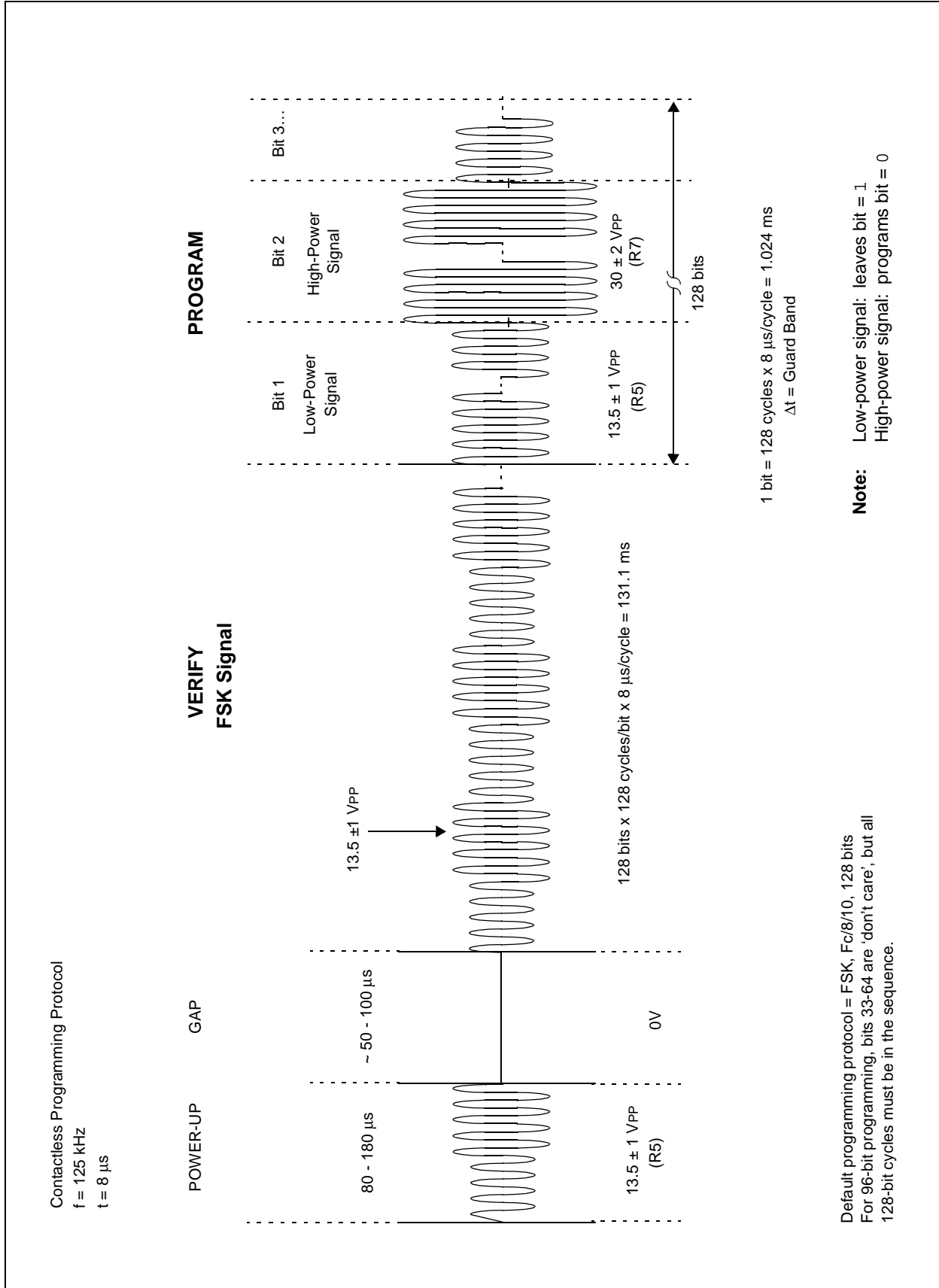

5.0 ANTI-COLLISION

The anti-collision feature is enabled after the array lock bit (CB12) is set. This feature relies on internal random number oscillator/counter and special gap pulses (= turn off RF field) provided by a reader. Figure 5-1 shows the anti-collision flowchart.

The MCRF250 works with the following anti-collision features:

1. The device does not output data until it sees the first gap. (no RF field for about 60 μ sec.)
2. When the device sees the first gap, the internal random number oscillator starts clocking immediately after the gap.
3. At the same time, the internal random number counter starts counting the random number clocks.
4. The device waits for 5 bit times (about 5 msec. for MOD128 configuration).

Example: 1 bit time=RF/128=1 msec for 128 kHz for MOD128

5. After the 5 bit times, the device sends data.
6. At this time, the random number counter is still running. If multiple tags in the field send data at the same time, the reader will see a data collision.
7. When the reader sees the data collision, it sends the second gap pulse. (no RF field for about 60 μ sec.)
8. After the second gap pulse, there is a chance that the random number counter of each tag may have a different value due to a random variation in the oscillator's starting time, etc.
9. After the second gap, the random number oscillator stops and the random number counter will decrement at each subsequent gap.
10. The device will transmit data when its random number counter reaches '0'.
11. The device repeats this sequence (as shown in the flowchart in Figure 5-1) according to the proper gap pulses provided by the reader.

Note: Each device will output data in different time frames since each random number counter will arrive at '0' at different times. As a result, the reader can receive clean data from a different tag in each time frame.

FIGURE 5-1: ANTI-COLLISION FLOWCHART

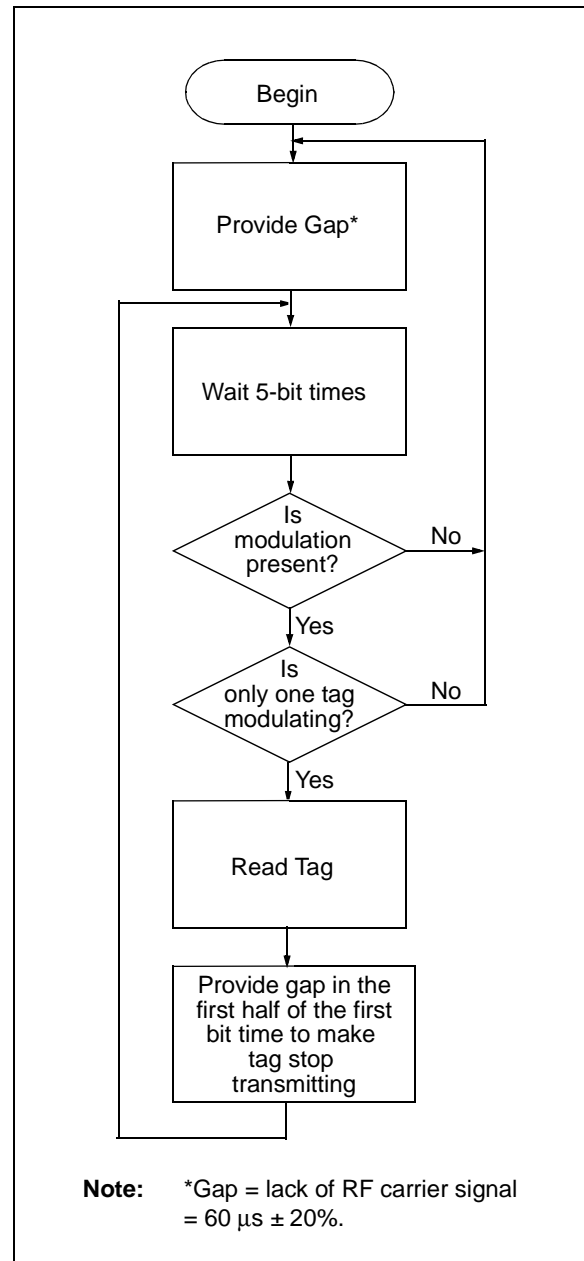

MCRF250

6.0 MECHANICAL SPECIFICATIONS FOR DIE AND WAFER

FIGURE 6-1: DIE PLOT

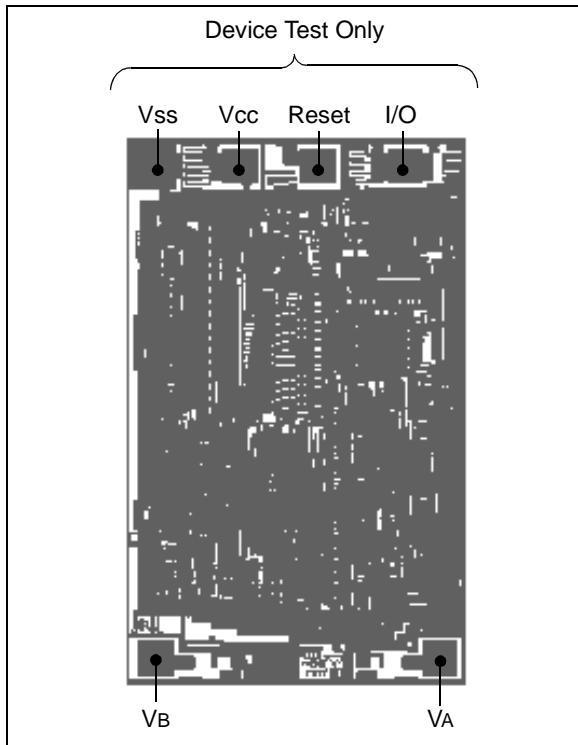

TABLE 6-1: PAD COORDINATES (μm)

Pad Name	Passivation Openings		Pad Center X	Pad Center Y
	Pad Width	Pad Height		
VA	90.0	90.0	427.50	-734.17
VB	90.0	90.0	-408.60	-734.17

Note 1: All coordinates are referenced from the center of the die.

Note 2: Die size: 1.1215 mm x 1.7384 mm.
44.15 mils x 68.44 mils

TABLE 6-2: PAD FUNCTION TABLE

Name	Function
VA	Antenna Coil connections
VB	
Vss	For device test only Do Not Connect to Antenna
VCC	
Reset	
I/O	

TABLE 6-3: DIE MECHANICAL DIMENSIONS

Specifications	Min	Typ	Max	Unit	Comments
Bond pad opening	— —	3.5 x 3.5 89 x 89	— —	mil μm	Note 1, Note 2
Die backgrind thickness	— —	7 177.8	— —	mil μm	Sawed 6" wafer on frame (option = WF) Note 3
	— —	11 279.4	— —	mil μm	Unsaed wafer (option = W) Note 3
Die backgrind thickness tolerance	— —	— —	±1 ±25.4	mil μm	
Die passivation thickness (multilayer)	—	0.9050	—	μm	Note 4
Die Size:					
Die size X*Y before saw (step size)	—	44.15 x 68.44	—	mil	—
Die size X*Y after saw	—	42.58 x 66.87	—	mil	—

- Note 1:** The bond pad size is that of the passivation opening. The metal overlaps the bond pad passivation by at least 0.1 mil.
- 2:** Metal Pad Composition is 98.5% Aluminum with 1% Si and 0.5% Cu.
- 3:** As the die thickness decreases, susceptibility to cracking increases. It is recommended that the die be as thick as the application will allow.
- 4:** The Die Passivation thickness can vary by device depending on the mask set used:
 -Layer 1: Oxide (undopped oxide, 0.135 μm)
 -Layer 2: PSG (dopped oxide, 0.43 μm)
 -Layer 3: Oxynitride (top layer, 0.34 μm)
- 5:** The conversion rate is 25.4 μm/mil.

Notice: Extreme care is urged in the handling and assembly of die products since they are susceptible to mechanical and electrostatic damage.

TABLE 6-4: WAFER MECHANICAL SPECIFICATIONS

Specifications	Min	Typ	Max	Unit	Comments
Wafer Diameter	—	8	—	inch	150 mm
Die separation line width	—	80	—	μm	
Dice per wafer	—	14,000	—	die	
Batch size	—	24	—	wafer	

7.0 FAILED DIE IDENTIFICATION

Every die on the wafer is electrically tested according to the data sheet specifications and visually inspected to detect any mechanical damage such as mechanical cracks and scratches.

Any failed die in the test or visual inspection is identified by black colored inking. Therefore, any die covered with black ink should not be used.

The ink dot specification:

- Ink dot size: minimum 20 μm x 20 μm
- Position: central third of die
- Color: black

8.0 WAFER DELIVERY DOCUMENTATION

Each wafer container is marked with the following information:

- Microchip Technology Inc. MP Code
- Lot Number
- Total number of wafer in the container
- Total number of good dice in the container
- Average die per wafer (DPW)
- Scribe number of wafer with number of good dice.

9.0 NOTICE ON DIE AND WAFER HANDLING

The device is very susceptible to Electrostatic Discharge (ESD). ESD can cause critical damage to the device. Special attention is needed during the handling process.

Any ultraviolet (UV) light can erase the memory cell contents of an unpackaged device. Fluorescent lights and sun light can also erase the memory cell although it takes more time than UV lamps. Therefore, keep any unpackaged devices out of UV light and also avoid direct exposure from strong fluorescent lights and sun light.

Certain integrated circuit (IC) manufacturing, chip-on-board (COB) and tag assembly operations may use UV light. Operations such as backgrind, de-tape, certain cleaning operations, epoxy or glue cure should be done without exposing the die surface to UV light.

Using x-ray for die inspection will not harm the die, nor erase memory cell contents.

10.0 PACKAGING INFORMATION

10.1 Package Marking Information

8-Lead PDIP (300 mil)

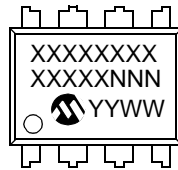

Example:

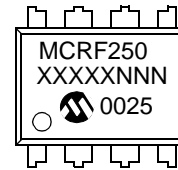

8-Lead SOIC (150 mil)

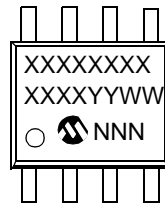

Example:

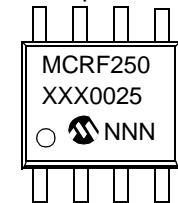

Legend:	XX...X	Customer specific information*
	Y	Year code (last digit of calendar year)
	YY	Year code (last 2 digits of calendar year)
	WW	Week code (week of January 1 is week '01')
	NNN	Alphanumeric traceability code
Note:	In the event the full Microchip part number cannot be marked on one line, it will be carried over to the next line thus limiting the number of available characters for customer specific information.	

* Standard device marking consists of Microchip part number, year code, week code, and traceability code.

MCRF250

8-Lead Plastic Dual In-line (P) – 300 mil (PDIP)

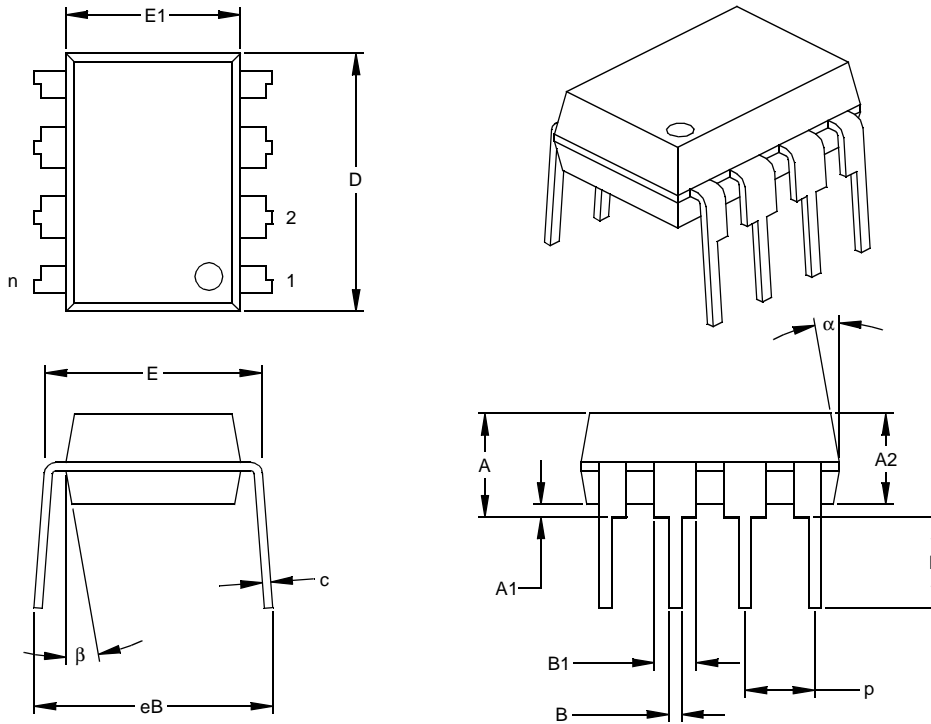

UNITS		INCHES*			MILLIMETERS		
DIMENSION LIMITS		MIN	NOM	MAX	MIN	NOM	MAX
Number of Pins	n		8			8	
Pitch	p		.100			2.54	
Top to Seating Plane	A	.140	.155	.170	3.56	3.94	4.32
Molded Package Thickness	A2	.115	.130	.145	2.92	3.30	3.68
Base to Seating Plane	A1	.015			0.38		
Shoulder to Shoulder Width	E	.300	.313	.325	7.62	7.94	8.26
Molded Package Width	E1	.240	.250	.260	6.10	6.35	6.60
Overall Length	D	.360	.373	.385	9.14	9.46	9.78
Tip to Seating Plane	L	.125	.130	.135	3.18	3.30	3.43
Lead Thickness	c	.008	.012	.015	0.20	0.29	0.38
Upper Lead Width	B1	.045	.058	.070	1.14	1.46	1.78
Lower Lead Width	B	.014	.018	.022	0.36	0.46	0.56
Overall Row Spacing	§ eB	.310	.370	.430	7.87	9.40	10.92
Mold Draft Angle Top	α	5	10	15	5	10	15
Mold Draft Angle Bottom	β	5	10	15	5	10	15

* Controlling Parameter

§ Significant Characteristic

Notes:

Dimensions D and E1 do not include mold flash or protrusions. Mold flash or protrusions shall not exceed .010" (0.254mm) per side.

JEDEC Equivalent: MS-001

Drawing No. C04-018

8-Lead Plastic Small Outline (SN) – Narrow, 150 mil (SOIC)

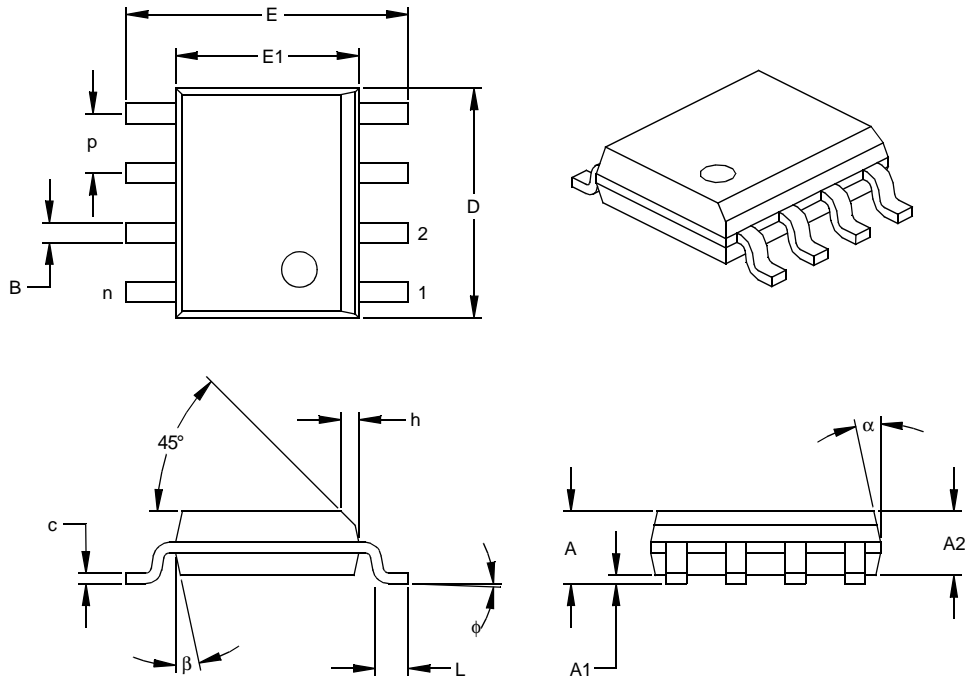

UNITS		INCHES*			MILLIMETERS		
DIMENSION LIMITS		MIN	NOM	MAX	MIN	NOM	MAX
Number of Pins	n		8			8	
Pitch	p		.050			1.27	
Overall Height	A	.053	.061	.069	1.35	1.55	1.75
Molded Package Thickness	A2	.052	.056	.061	1.32	1.42	1.55
Standoff §	A1	.004	.007	.010	.10	.18	.25
Overall Width	E	.228	.237	.244	5.79	6.02	6.20
Molded Package Width	E1	.146	.154	.157	3.71	3.91	3.99
Overall Length	D	.189	.193	.197	4.80	4.90	5.00
Chamfer Distance	h	.010	.015	.020	.25	.38	.51
Foot Length	L	.019	.025	.030	.48	.62	.76
Foot Angle	φ	0	4	8	0	4	8
Lead Thickness	c	.008	.009	.010	.20	.23	.25
Lead Width	B	.013	.017	.020	.33	.42	.51
Mold Draft Angle Top	α	0	12	15	0	12	15
Mold Draft Angle Bottom	β	0	12	15	0	12	15

* Controlling Parameter
 § Significant Characteristic

Notes:

Dimensions D and E1 do not include mold flash or protrusions. Mold flash or protrusions shall not exceed .010" (0.254mm) per side.
 JEDEC Equivalent: MS-012
 Drawing No. C04-057

MCRF250

1M/3M COB (IOA2)

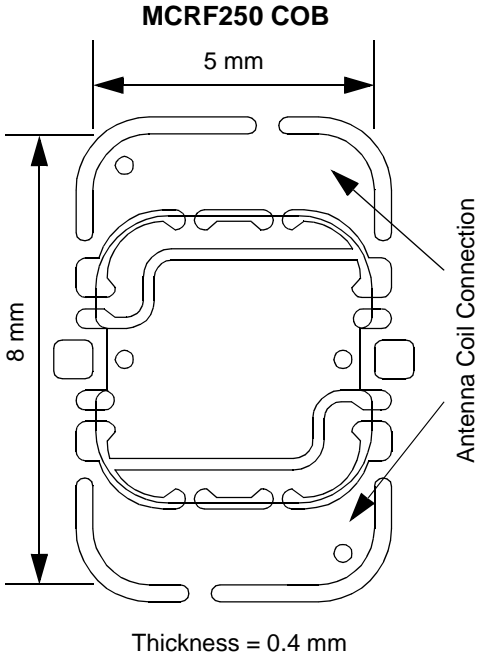

ON-LINE SUPPORT

Microchip provides on-line support on the Microchip World Wide Web site.

The web site is used by Microchip as a means to make files and information easily available to customers. To view the site, the user must have access to the Internet and a web browser, such as Netscape® or Microsoft® Internet Explorer. Files are also available for FTP download from our FTP site.

Connecting to the Microchip Internet Web Site

The Microchip web site is available at the following URL:

www.microchip.com

The file transfer site is available by using an FTP service to connect to:

<ftp://ftp.microchip.com>

The web site and file transfer site provide a variety of services. Users may download files for the latest Development Tools, Data Sheets, Application Notes, User's Guides, Articles and Sample Programs. A variety of Microchip specific business information is also available, including listings of Microchip sales offices, distributors and factory representatives. Other data available for consideration is:

- Latest Microchip Press Releases
- Technical Support Section with Frequently Asked Questions
- Design Tips
- Device Errata
- Job Postings
- Microchip Consultant Program Member Listing
- Links to other useful web sites related to Microchip Products
- Conferences for products, Development Systems, technical information and more
- Listing of seminars and events

SYSTEMS INFORMATION AND UPGRADE HOT LINE

The Systems Information and Upgrade Line provides system users a listing of the latest versions of all of Microchip's development systems software products. Plus, this line provides information on how customers can receive the most current upgrade kits. The Hot Line Numbers are:

1-800-755-2345 for U.S. and most of Canada, and

1-480-792-7302 for the rest of the world.

042003

MCRF250

READER RESPONSE

It is our intention to provide you with the best documentation possible to ensure successful use of your Microchip product. If you wish to provide your comments on organization, clarity, subject matter, and ways in which our documentation can better serve you, please FAX your comments to the Technical Publications Manager at (480) 792-4150.

Please list the following information, and use this outline to provide us with your comments about this document.

To: Technical Publications Manager
RE: Reader Response
Total Pages Sent _____

From: Name _____
Company _____
Address _____
City / State / ZIP / Country _____
Telephone: (_____) _____ - _____ FAX: (_____) _____ - _____

Application (optional):

Would you like a reply? ___Y ___N

Device: MCRF250

Literature Number: DS21267F

Questions:

1. What are the best features of this document?

2. How does this document meet your hardware and software development needs?

3. Do you find the organization of this document easy to follow? If not, why?

4. What additions to the document do you think would enhance the structure and subject?

5. What deletions from the document could be made without affecting the overall usefulness?

6. Is there any incorrect or misleading information (what and where)?

7. How would you improve this document?

PRODUCT IDENTIFICATION SYSTEM

To order or obtain information, e.g., on pricing or delivery, refer to the factory or the listed sales office.

<u>PART NO.</u>	<u>-X</u>	<u>/XXX</u>	<u>XXX</u>
Device	Temperature Range	Package	Configuration/SQTP Code
Device:	MCRF250 = 125 kHz Anticollision MicroID tag, 96/128-bit		
Temperature Range:	I = -40°C to +85°C		
Package:	WF = Sawed wafer on frame (7 mil backgrind) W = Wafer (11 mil backgrind) S = Dice in wafer pack P = Plastic PDIP (300 mil Body) 8-lead SN = Plastic SOIC (150 mil Body) 8-lead		
Configuration:	Three-digit hex value to be programmed into the configuration register. Three hex characters correspond to 12 binary bits. These bits are programmed into the configuration register MSB first (CB12, CB11...CB1). Refer to example.		
SQTP Code:	An assigned, customer 3-digit code used for tracking and controlling production and customer data files for factory programming. In this case the configuration code is not shown in the part number, but is captured in the SQTP documentation.		
Examples:			
a) MCRF250-I/W40A = 125 kHz, industrial temperature, wafer package, contactlessly programmable, 96 bit, FSK Fc/8 Fc/10, direct encoded, Fc/50 data return rate tag.			
b) MCRF250-I/WFQ23 = 125 kHz, industrial temperature, wafer sawn and mounted on frame, factory programmed.			
The configuration register is:			
CB12 CB11 CB10 CB9 CB8 CB7 CB6 CB5 CB4 CB3 CB2 CB1 0 1 0 0 0 0 0 0 0 1 0 1 0			

Sales and Support

Data Sheets

Products supported by a preliminary Data Sheet may have an errata sheet describing minor operational differences and recommended workarounds. To determine if an errata sheet exists for a particular device, please contact one of the following:

1. Your local Microchip sales office
2. The Microchip Corporate Literature Center U.S. FAX: (480) 792-7277
3. The Microchip Worldwide Site (www.microchip.com)

Please specify which device, revision of silicon and Data Sheet (include Literature #) you are using.

New Customer Notification System

Register on our web site (www.microchip.com/cn) to receive the most current information on our products.

MCRF250

NOTES:

Note the following details of the code protection feature on Microchip devices:

- Microchip products meet the specification contained in their particular Microchip Data Sheet.
- Microchip believes that its family of products is one of the most secure families of its kind on the market today, when used in the intended manner and under normal conditions.
- There are dishonest and possibly illegal methods used to breach the code protection feature. All of these methods, to our knowledge, require using the Microchip products in a manner outside the operating specifications contained in Microchip's Data Sheets. Most likely, the person doing so is engaged in theft of intellectual property.
- Microchip is willing to work with the customer who is concerned about the integrity of their code.
- Neither Microchip nor any other semiconductor manufacturer can guarantee the security of their code. Code protection does not mean that we are guaranteeing the product as "unbreakable."

Code protection is constantly evolving. We at Microchip are committed to continuously improving the code protection features of our products. Attempts to break microchip's code protection feature may be a violation of the Digital Millennium Copyright Act. If such acts allow unauthorized access to your software or other copyrighted work, you may have a right to sue for relief under that Act.

Information contained in this publication regarding device applications and the like is intended through suggestion only and may be superseded by updates. It is your responsibility to ensure that your application meets with your specifications. No representation or warranty is given and no liability is assumed by Microchip Technology Incorporated with respect to the accuracy or use of such information, or infringement of patents or other intellectual property rights arising from such use or otherwise. Use of Microchip's products as critical components in life support systems is not authorized except with express written approval by Microchip. No licenses are conveyed, implicitly or otherwise, under any intellectual property rights.

Trademarks

The Microchip name and logo, the Microchip logo, Accuron, dsPIC, KEELOQ, MPLAB, PIC, PICmicro, PICSTART, PRO MATE and PowerSmart are registered trademarks of Microchip Technology Incorporated in the U.S.A. and other countries.

AmpLab, FilterLab, microID, MXDEV, MXLAB, PICMASTER, SEEVAL, SmartShunt and The Embedded Control Solutions Company are registered trademarks of Microchip Technology Incorporated in the U.S.A.

Application Maestro, dsPICDEM, dsPICDEM.net, dsPICworks, ECAN, ECONOMONITOR, FanSense, FlexROM, fuzzyLAB, In-Circuit Serial Programming, ICSP, ICEPIC, microPort, Migratable Memory, MPASM, MPLIB, MPLINK, MPSIM, PICKit, PICDEM, PICDEM.net, PICTail, PowerCal, PowerInfo, PowerMate, PowerTool, rfLAB, rfPIC, Select Mode, SmartSensor, SmartTel and Total Endurance are trademarks of Microchip Technology Incorporated in the U.S.A. and other countries.

Serialized Quick Turn Programming (SQTP) is a service mark of Microchip Technology Incorporated in the U.S.A.

All other trademarks mentioned herein are property of their respective companies.

© 2003, Microchip Technology Incorporated, Printed in the U.S.A., All Rights Reserved.

 Printed on recycled paper.

**QUALITY MANAGEMENT SYSTEM
CERTIFIED BY DNV
== ISO/TS 16949:2002 ==**

Microchip received ISO/TS-16949:2002 quality system certification for its worldwide headquarters, design and wafer fabrication facilities in Chandler and Tempe, Arizona and Mountain View, California in October 2003. The Company's quality system processes and procedures are for its PICmicro® 8-bit MCUs, KEELOQ® code hopping devices, Serial EEPROMs, microperipherals, non-volatile memory and analog products. In addition, Microchip's quality system for the design and manufacture of development systems is ISO 9001:2000 certified.



WORLDWIDE SALES AND SERVICE

AMERICAS

Corporate Office

2355 West Chandler Blvd.
Chandler, AZ 85224-6199
Tel: 480-792-7200
Fax: 480-792-7277
Technical Support: 480-792-7627
Web Address: <http://www.microchip.com>

Atlanta

3780 Mansell Road, Suite 130
Alpharetta, GA 30022
Tel: 770-640-0034
Fax: 770-640-0307

Boston

2 Lan Drive, Suite 120
Westford, MA 01886
Tel: 978-692-3848
Fax: 978-692-3821

Chicago

333 Pierce Road, Suite 180
Itasca, IL 60143
Tel: 630-285-0071
Fax: 630-285-0075

Dallas

4570 Westgrove Drive, Suite 160
Addison, TX 75001
Tel: 972-818-7423
Fax: 972-818-2924

Detroit

Tri-Atria Office Building
32255 Northwestern Highway, Suite 190
Farmington Hills, MI 48334
Tel: 248-538-2250
Fax: 248-538-2260

Kokomo

2767 S. Albright Road
Kokomo, IN 46902
Tel: 765-864-8360
Fax: 765-864-8387

Los Angeles

18201 Von Karman, Suite 1090
Irvine, CA 92612
Tel: 949-263-1888
Fax: 949-263-1338

Phoenix

2355 West Chandler Blvd.
Chandler, AZ 85224-6199
Tel: 480-792-7966
Fax: 480-792-4338

San Jose

1300 Terra Bella Avenue
Mountain View, CA 94043
Tel: 650-215-1444

Toronto

6285 Northam Drive, Suite 108
Mississauga, Ontario L4V 1X5, Canada
Tel: 905-673-0699
Fax: 905-673-6509

ASIA/PACIFIC

Australia

Suite 22, 41 Rawson Street
Epping 2121, NSW
Australia
Tel: 61-2-9868-6733
Fax: 61-2-9868-6755

China - Beijing

Unit 706B
Wan Tai Bei Hai Bldg.
No. 6 Chaoyangmen Bei Str.
Beijing, 100027, China
Tel: 86-10-85282100
Fax: 86-10-85282104

China - Chengdu

Rm. 2401-2402, 24th Floor,
Ming Xing Financial Tower
No. 88 TIDU Street
Chengdu 610016, China
Tel: 86-28-86766200
Fax: 86-28-86766599

China - Fuzhou

Unit 28F, World Trade Plaza
No. 71 Wusi Road
Fuzhou 350001, China
Tel: 86-591-7503506
Fax: 86-591-7503521

China - Hong Kong SAR

Unit 901-6, Tower 2, Metroplaza
223 Hing Fong Road
Kwai Fong, N.T., Hong Kong
Tel: 852-2401-1200
Fax: 852-2401-3431

China - Shanghai

Room 701, Bldg. B
Far East International Plaza
No. 317 Xian Xia Road
Shanghai, 200051
Tel: 86-21-6275-5700
Fax: 86-21-6275-5060

China - Shenzhen

Rm. 1812, 18/F, Building A, United Plaza
No. 5022 Binhe Road, Futian District
Shenzhen 518033, China
Tel: 86-755-82901380
Fax: 86-755-8295-1393

China - Shunde

Room 401, Hongjian Building
No. 2 Fengxiangnan Road, Ronggui Town
Shunde City, Guangdong 528303, China
Tel: 86-765-8395507 Fax: 86-765-8395571

China - Qingdao

Rm. B505A, Fullhope Plaza,
No. 12 Hong Kong Central Rd.
Qingdao 266071, China
Tel: 86-532-5027355 Fax: 86-532-5027205

India

Divyasree Chambers
1 Floor, Wing A (A3/A4)
No. 11, O'Shaughnessey Road
Bangalore, 560 025, India
Tel: 91-80-2290061 Fax: 91-80-2290062

Japan

Benex S-1 6F
3-18-20, Shinyokohama
Kohoku-Ku, Yokohama-shi
Kanagawa, 222-0033, Japan
Tel: 81-45-471-6166 Fax: 81-45-471-6122

Korea

168-1, Youngbo Bldg. 3 Floor
Samsung-Dong, Kangnam-Ku
Seoul, Korea 135-882
Tel: 82-2-554-7200 Fax: 82-2-558-5932 or
82-2-558-5934

Singapore

200 Middle Road
#07-02 Prime Centre
Singapore, 188980
Tel: 65-6334-8870 Fax: 65-6334-8850

Taiwan

Kaohsiung Branch
30F - 1 No. 8
Min Chuan 2nd Road
Kaohsiung 806, Taiwan
Tel: 886-7-536-4818
Fax: 886-7-536-4803

Taiwan

Taiwan Branch
11F-3, No. 207
Tung Hua North Road
Taipei, 105, Taiwan
Tel: 886-2-2717-7175 Fax: 886-2-2545-0139

EUROPE

Austria

Durisolstrasse 2
A-4600 Wels
Austria
Tel: 43-7242-2244-399
Fax: 43-7242-2244-393

Denmark

Regus Business Centre
Lautrup høj 1-3
Ballerup DK-2750 Denmark
Tel: 45-4420-9895 Fax: 45-4420-9910

France

Parc d'Activite du Moulin de Massy
43 Rue du Saule Trapu
Batiment A - 1er Etage
91300 Massy, France
Tel: 33-1-69-53-63-20
Fax: 33-1-69-30-90-79

Germany

Steinheilstrasse 10
D-85737 Ismaning, Germany
Tel: 49-89-627-144-0
Fax: 49-89-627-144-44

Italy

Via Quasimodo, 12
20025 Legnano (MI)
Milan, Italy
Tel: 39-0331-742611
Fax: 39-0331-466781

Netherlands

P. A. De Biesbosch 14
NL-5152 SC Drunen, Netherlands
Tel: 31-416-690399
Fax: 31-416-690340

United Kingdom

505 Eskdale Road
Winnersh Triangle
Wokingham
Berkshire, England RG41 5TU
Tel: 44-118-921-5869
Fax: 44-118-921-5820

11/24/03